



# Winco's Transira™ Retrofit Window Solution



## Control Pathogens, Add Security While Keeping Existing Window Systems

There's a new high-tech way to add health safety, security and energy upgrades to existing window systems. WINCO's new Transira™ Window Solutions program integrates a motorized, high-tech shading system inside a custom-made window, and then integrates motor controls that can be controlled as a part of building's management system.

If your building's windows are functional, yet need an upgrade, a Transira Accessory Window offers the best of all worlds. The retrofit configuration can be used with new or existing storefront, curtainwall or inboard of existing primary windows.

WINCO's Transira Accessory Sash is an economical way to increase energy savings, reduce health concerns with an allergen and improve pathogen-resistance to a space, and add visual intruder security. Add in one-touch motor controls by leading control manufacturer Somfy, and your windows are transformed from static to state-of-the-art!

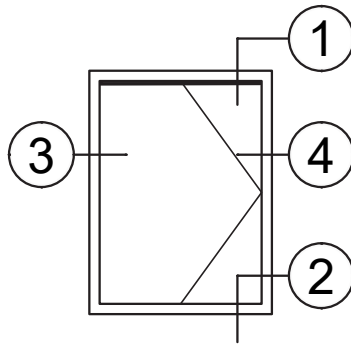

The Retrofit Configuration is designed to be used in conjunction with new or existing Storefront, Curtain Wall or inboard of existing primary windows. While the accessory sash containing the motorized shade can be opened for maintenance purposes, it is not intended to be opened for ventilation. Shimming not shown for clarity of system.

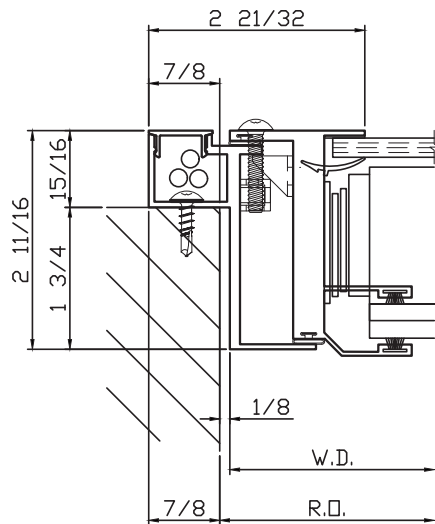
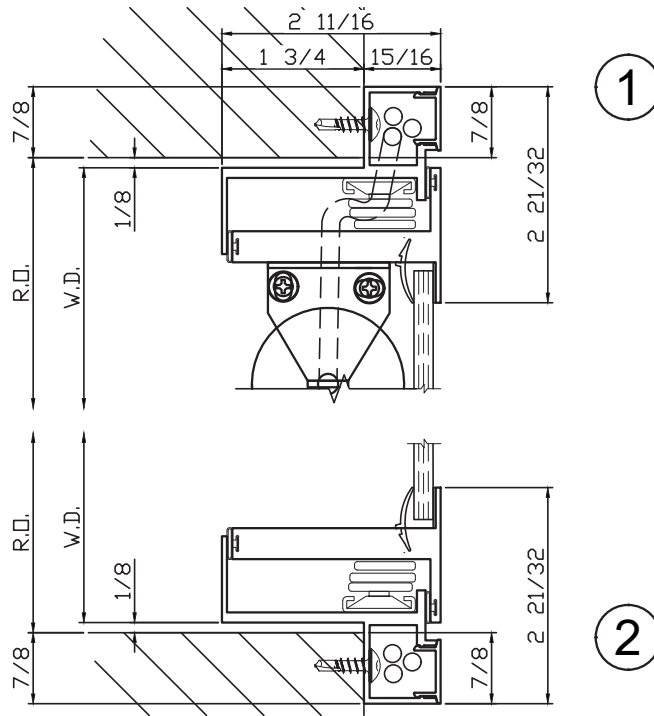

3

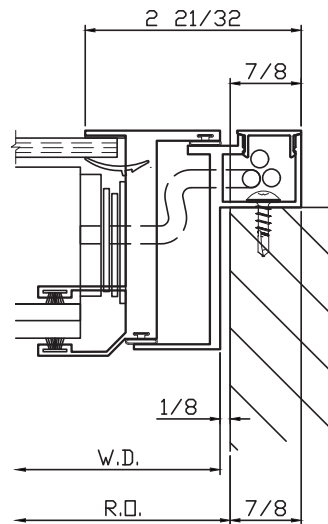

4

Transira™ Window solution by WINCO Window Company is a new total fenestration solution that can provide increased energy savings, improved security and help control allergens. The new smart window system combines an integrated shade between two glass lites which can be controlled with the touch of a button. The Transira Window solution can be used in both new construction and retrofit projects and are ideal for schools, hospitals, office buildings, hospitality projects, high risk buildings and other applications.