



# Series 4500

4" Architectural Grade Thermal Window System  
Fixed-Double Hung



## Product Overview

The 4500 Series is a fixed and double-hung window that has been designed to provide years of low maintenance performance. With 0.080" nominal wall thickness throughout the mainframe and sash and a 1/8" thick aluminum sill, the 4500 is up to the task that monumental window designs require.

GREEN COMMITMENT

HISTORIC REPLICATION

NOISE CONTROL

BLAST SHIELD

## Features & Custom Options

- Azon "Azo-Brader" thermally broken frame and sash, backed by a 10 year warranty against thermal break shrinkage
- Vertical and horizontal stacking members
- Integral lift handle on operable sash
- 4 sided fin seal weather-strip on the exterior
- Various glazing thicknesses available
- Dual glazing with optional integral blinds providing dynamic light control
- Accessory line of receptors, mullions, panning and trim for a customized look
- Laminated glass, blast mitigation and ballistic glazing are available
- Optional aluminum extruded screens
- Accompanying fixed frame options

## Performance Data\*

Type	Air (CFM/FT2 @ 6.24 PSF)	Water (PSF)	Structural (PSF)	CRF	U-Value (Btu/Hr-Ft <sup>2</sup> -°F)	STC
AW-PG60-Hung	Less than 0.10	10 (Higher levels may be available upon request)	+/- 90	58*	0.42*	Contact your local Rep

\*U-Value, CRF, Water and AW ratings are based on a particular type of glazing and window configuration being used. They are provided for comparison purposes only. They are based on products of standard configuration, tested in accordance with NFRC/FGIA/AAMA specifications, in a laboratory environment under optimum conditions. Performance values will vary according to project specifications, installation, size, configuration, hardware, glass, etc. Any required field testing should be done in accordance with the project specifications and FGIA/AAMA field testing protocol, not this data.



# Series 4500 Detail Drawings

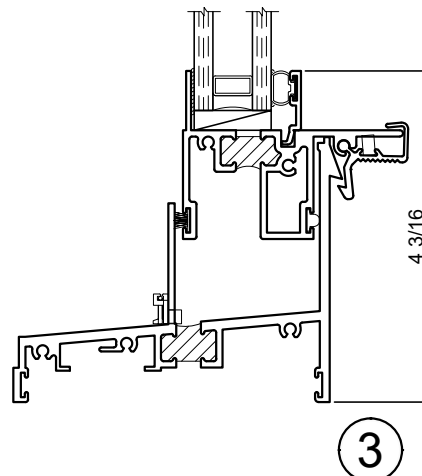
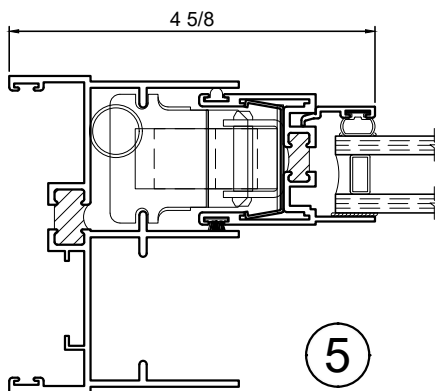
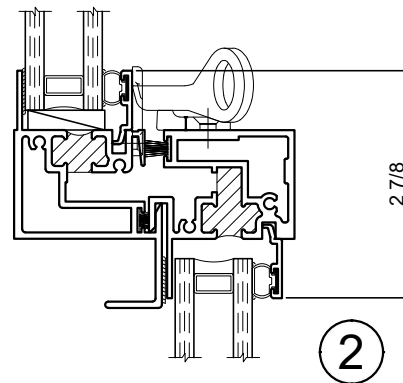
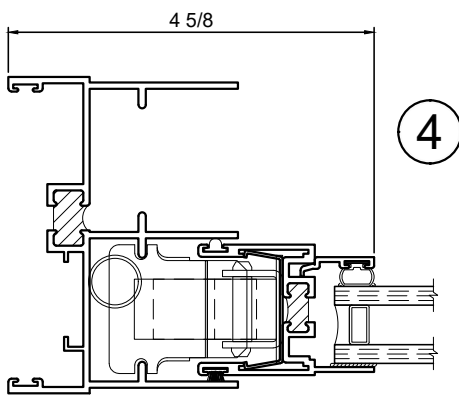
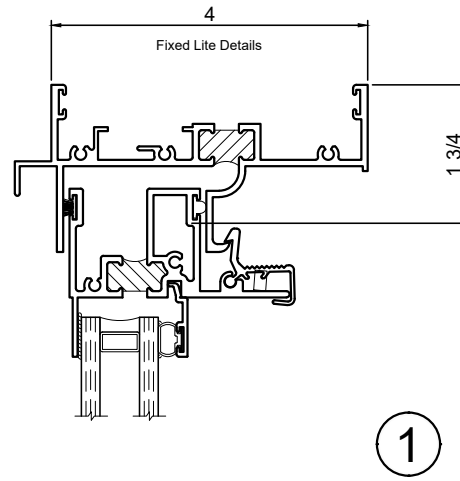
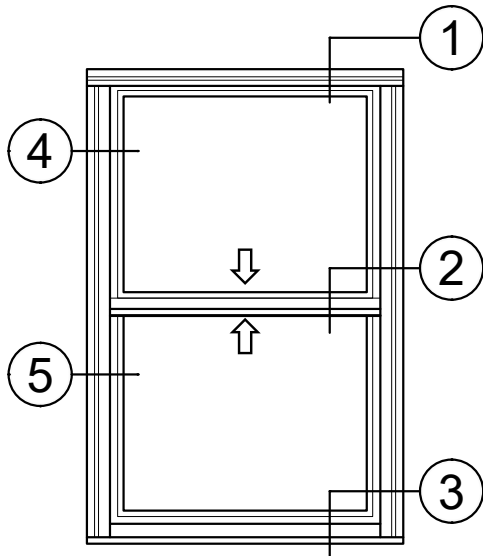

Winco Window Company  
6200 Maple Avenue  
St Louis, MO 63130

TESTING: Our products meet stringent testing requirements of both the American Architectural Manufacturers Association (AAMA) and the National Fenestration Rating Council (NFRC) standards and certification.

